

Painel Policristalino

Módulo Solar PV

144 Cells - 200W

The main features



Power and tolerance

0~+3W positive power tolerance guarantee



Resistance to the PID

Harsh conditions for 96 hours testing qualified (@ 85 °C / 85%). For special severity Installation environment, can meet higher standards



Stronger surface resistance to mechanical loads

It has passed the certification of 6000Pa snow load and 3600Pa wind load



High reliability and weather resistance

Through dust, salt fog, ammonia corrosion test, can effectively deal with the harsh environment



The hail test

It passed the hail test with a diameter of 45mm and a speed of 30.7m/s



Lower temperature coefficient

Better temperature coefficient makes the power attenuation less at high temperature

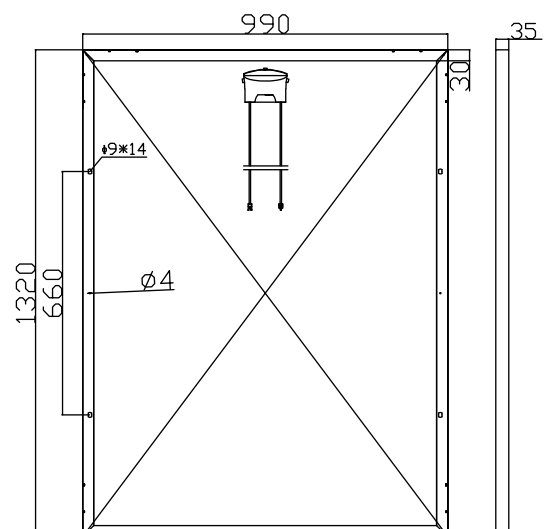
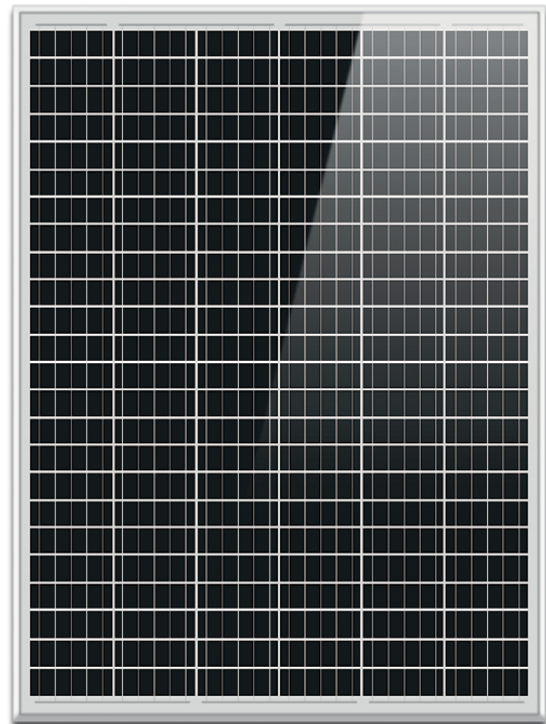

Best quality assurance

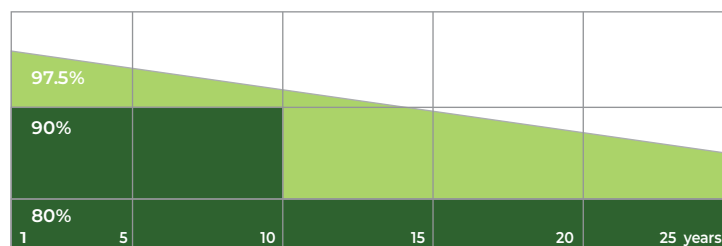

Linear power output warranty

Industry quality assurance

12 years of product material and process quality assurance
25 years linear power output warranty



POLYCRYSTALLINE 200W

MODEL	SN-P200
Maximum Power/Pmax(Wp)	200
Optimum Operating Voltage/Vmp(V)	36.0
Optimum Operating Current/Imp(A)	5.6
Open Circuit Voltage/Voc(V)	43.2
Short Circuit Current/Isc(A)	6.1
Cell Efficiency	17.12%
Module Efficiency	15.30%
Power Tolerance	0~+3W
Maximum Series Fuse Rating(A)	15A
Maximum System Voltage	1000VDC

MAXIMUM DATA

Operating Module Temperature	-40 °C to +80 °C	°C
Storage Temperature	From -40 °C to +80 °C	°C
Insulation Cut Voltage	1000	DC
Maximum Wind Resistance	60m/s	N/m ² or max KM/h
Surface Maximum Load Capacity	200	Kg/m ²
Maximum Hail Load Capacity	5mm	80km/h

MECHANICAL CHARACTERISTICS

Number of cells	144(24*6)
Cell Dimension(mm)	52*156
Dimension(mm)	1320*990*35
Weight(Kg)	16.5
Frame Material	Clear anodized aluminium frame
Thickness of Glass	3.2mm tempered glass
Frame	Anodized aluminum alloy
Laminating Material	EVA (Light transmittance more than 92%)
Backsheet Material	TPT (High weather resistance)
Junction Box	Ip65 (1500V system voltage available)
Output cable	90cm 2x4.0mm ² MC4 connector
Bus Bar	5BB